

Features:

- AAMA standard Tested and Certified
- Structural thermal breaks
- Coped corner screw spline design
- Positive meeting rail interlock
- Full width pull handles
- Equal length master frame legs
- Poured and debridged thermal break
- Thermal break debridging is not exposed
- Double fin type weather stripping
- 1" sealed insulating glass per ASTM E 2190-02
- Aluminum glazing beads with dual durometer bulb
- Cast white bronze cam type locking handles
- Manufactured on 1/8" increments
- Screens with charcoal colored fiberglass mesh
- XO, XO, XOX or OXO Sliding windows
- Kynar 2605 finish in 25 standard colors.

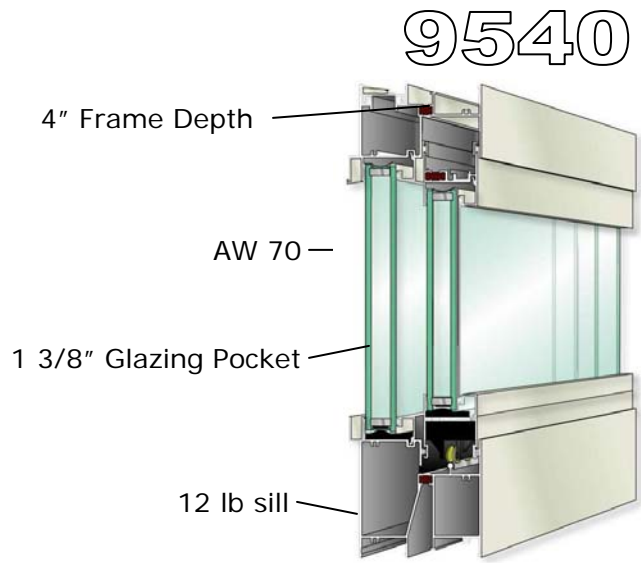

Options:

- Snap-in front flange panning legs with 1 1/4" extensions for head, jamb, sill or all locations
- Snap-in nailing fins (field applied)
- Slide on strap anchors with 1 1/4" extension beyond interior face of the window
- Integral mulling of window types in same master frame
- All commercially available glazing materials
- 1 3/8" glass pocket for glazing exterior applied grids and maintains 1" insulating glass
- Single glazing
- Between-the-glass muntins
- Exterior-applied muntins in 4 different widths
- True muntins 2 7/16" sightline (all models)
- 1/4", 1", 1 3/8" 1 1/2" insulated panels
- Split sash designs with dual glazing to accommodate polycarbonate glazing
- Split sash designs to accommodate 5/8" depth between glass blinds and interior lift out panel design
- Cast bronze auto locks or extruded auto locks
- Limited sash travel
- Maintenance-only cast bronze "allen keyed" security locks at meeting rail
- Various structural mullions for joining multiple windows in an opening
- Receptor Systems
- Standard and custom panning systems
- Interior trim systems
- Sub-sills
- Project specific custom extrusions
- Aluminum, stainless steel or solar screen mesh
- Custom colors, 2603 Fluorocryl, 2604 Kynar and anodized finishes.