

Features:

- AAMA standard Tested and Certified
- 2 1/2" frame depth- G100 polyamide strip thermal breaks
- 3 1/4" frame depth- G200 polyamide strip thermal breaks
- Interlocking two piece adjustable corner key design
- Euro-groove locking hardware
- Frame center vent Santoprene weather stripping
- Equal length master frame legs
- 1" sealed insulating glass per ASTM E 2190-02
- Aluminum glazing beads with dual durometer bulb
- Manufactured on 1/8" increments
- Vent screens with charcoal colored fiberglass mesh
- Kynar 2605 finish in 25 standard colors

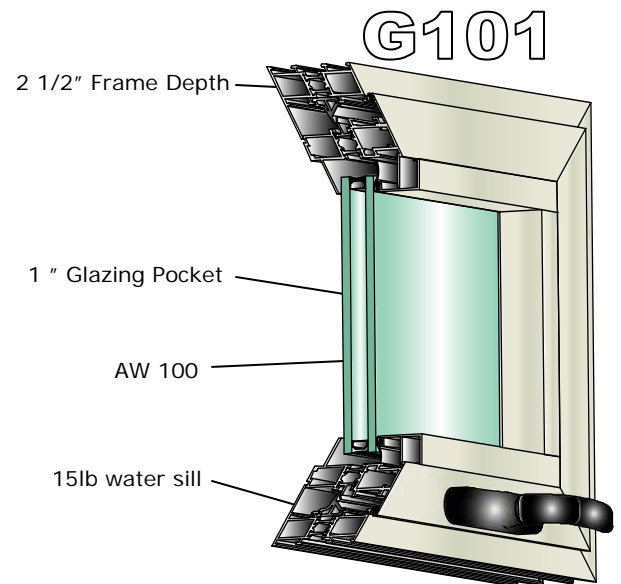

Options:

- 3 1/4" frame depth-G300 & G400 advanced polyamide strip thermal breaks
- All commercially available glazing materials
- 1" glass pocket for glazing exterior applied grids
- Between-the-glass muntins in 2 different widths
- Exterior-applied, in between glass, and tape applied muntins in various widths
- 1" insulated panels
- Various structural mullions for joining multiple windows in an opening
- Receptor Systems
- Standard and custom panning systems
- Interior trim systems
- Sub-sills
- Project specific custom extrusions
- Aluminum, stainless steel or solar screen mesh
- Custom colors, 2603 Flurocryn, 2604 Kynar, and anodized finishes
- Two different color combinations for interior and exterior –both painted, one painted/one anodized, and one painted/ one simulated wood grain on Aluminum at interior frame only

