

Features:

- AAMA standard tested and certified
- Master frame wall thickness 0.125"
- Vent frame wall thickness 0.125"
- Structural thermal breaks
- Off-set frame/vent design
- Butt construction and triple screwed master frame corner design
- Vents are miter-cut, joined with an extruded aluminum corner key and mechanically crimped
- Equal length master frame legs
- Unique 4-raceway thermal break cavity design with 1/4" debridging
- Thermal break debridging is not exposed
- Santoprene bulb weather-stripping
- 1" sealed insulating glass per ASTM E 2190-02
- Aluminum glazing beads with Santoprene bulbs
- Heavy-duty stainless steel 4-bar Anderberg type hinges with friction adjustment
- Cast white bronze cam type locking handles
- Friction adjuster/limit device
- Manufactured on 1/8" increments
- Kynar 2605 finish in 25 standard colors.

1811

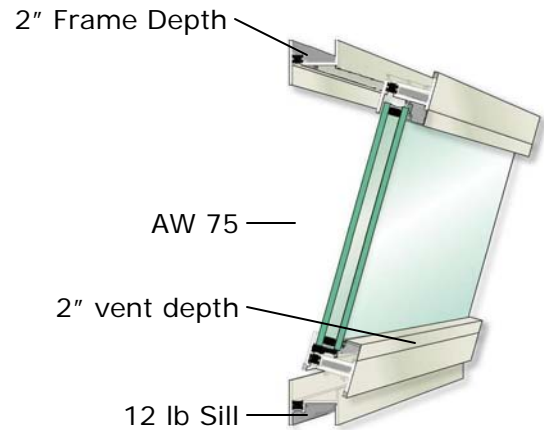

Options:

- Integral mulling of awning (POB), hopper (PIT), casements and fixed in same master frame
- All commercially available glazing materials
- 1 3/8" insulating glass
- 1 3/8" glass pocket for glazing exterior applied grids and maintains 1" insulating glass
- Single glazing
- Between-the-glass muntins
- Exterior-applied muntins in 4 different widths
- 1/4", 1", 1 3/8" 1 1/2" insulated panels
- Split sash designs with dual glazing to accommodate polycarbonate glazing
- Split sash designs to accommodate 5/8" depth between the glass blinds
- Custodial locks (key operated)
- Multi-point locks
- Life safety opening limiter
- Egress hinges with or without washability
- Extruded aluminum butt hinges with stainless steel pin and nylon bushings in lieu of the standard 4-bar hinges
- Strap anchors to facilitate installation in new construction
- Various structural mullions for joining multiple windows in an opening
- Receptor Systems
- Standard and custom panning systems
- Interior trim systems
- Sub-sills
- Applied interior or interior wicket-type screens
- Exterior Screens with Charcoal colored fiberglass (standard) aluminum, stainless steel or solar screen mesh
- Custom colors, 2603 Fluorocryl, 2604 Kynar and anodized finishes.

1911

